

HUMBER MK. III REFLECTOR BINNACLE WITH TYPE 161A COMPASS

Laminated Glass Fibre Binnacle in attractive White Finish
with High Density PVC and Brass Deckhead Reflector Unit.

STANDARD EQUIPMENT.

TYPE 161A SPIRIT COMPASS with 165 mm Dia. Card 0-360° with 1/4 Pts. Suspended in Gimbal using Phosphor Bronze Bearings.
Diameters :- Bowl 246 mm Gimbal 304 mm.

Binnacle - Main and Emergency Lighting. Iron Spheres and Flinders Bar. Heeling Error Tube and Magnets. Full Set Compensating Magnets. Brass Fixing Bolts with Deck Plates. Angled Mirror for height of eye adjustment. Special access tube for TMC wiring. Two cable tubes for lighting wiring.

WEIGHT.

Binnacle including all compensation devices.
Patt.161A Compass and Reflector Unit 74.5kg
Patt.161A Compass 12kg

OPTIONAL EXTRAS.

Electrical Dimmer (Specify Voltage)
Azimuth Mirror Cast Brass Ring Pattern with Shadow Pin. In Wood Case.
Pelorus 7" diameter dial, folding sight supplied with Port, Starboard and Stowage Brackets.
Spare Compass Pattern 161A with Gimbal in wood Stowage Case.

ONBOARD SPARES.

1 - Glass
1 - Gasket
1 - Pivot
1 - Sapphire

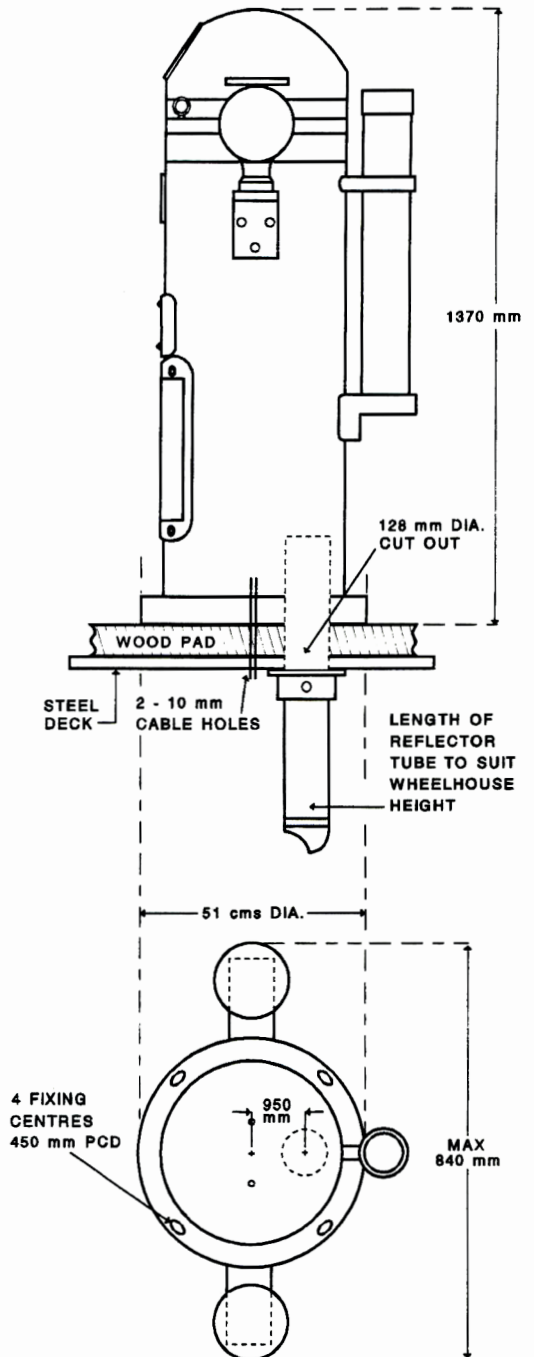

The Humber Mk. III Binnacle can also be supplied without Deckhead Reflector Unit, for Steering or Standard Positions.

KINDLY STATE WHEN ORDERING:

- 1) Thickness off Pad. _____
- 2) Height of Wheelhouse. _____
- 3) 'Dimension' Steel Deckhead to centre of Mirror of Ref. Tube. _____

HUMBER MK. III REFLECTOR BINNACLE WITH TYPE 161A COMPASS

Holding

Norwegian,
Chinese etc.
type
approval.

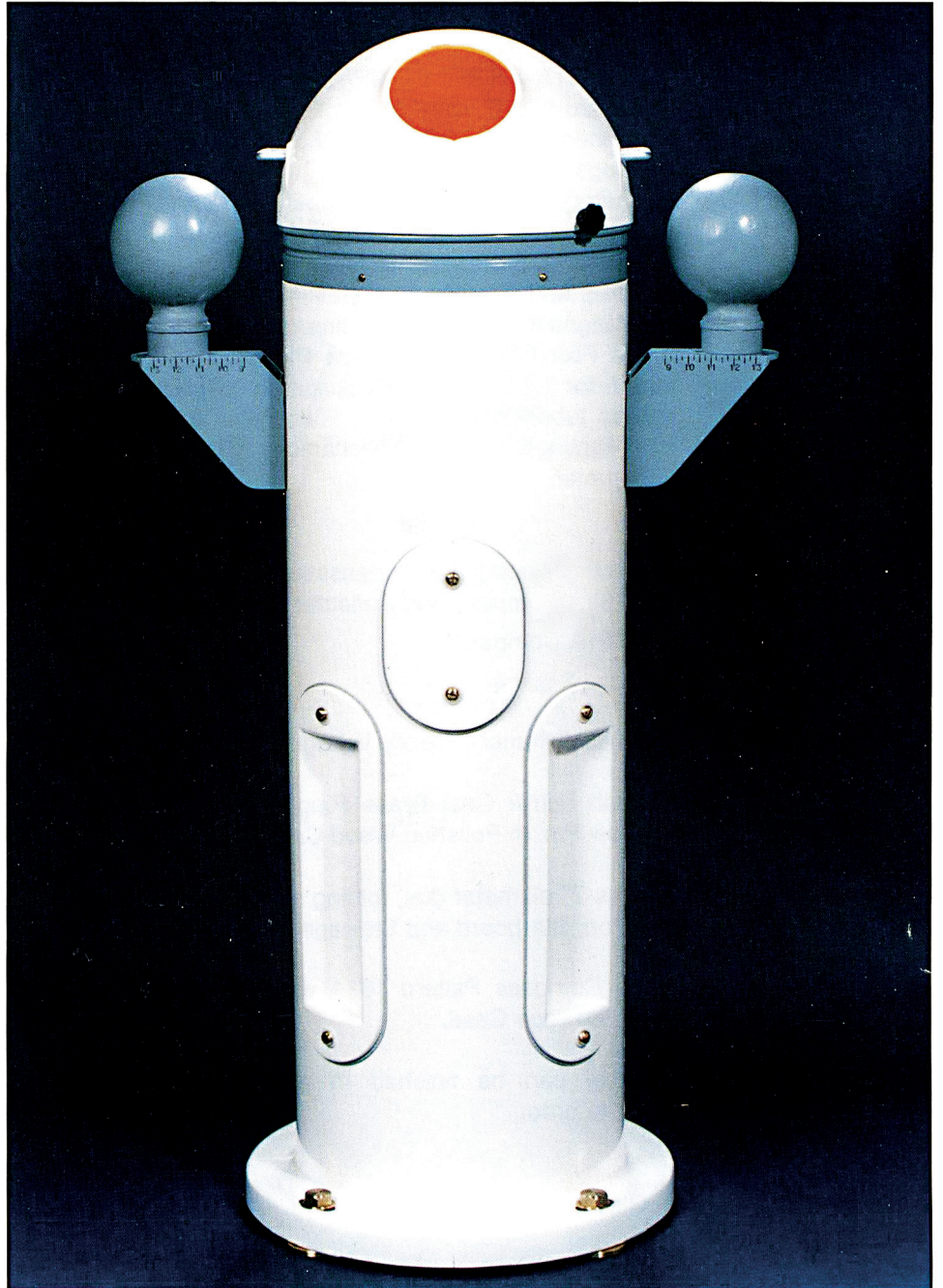

Established 1863

B. COOKE & SON LTD.

KINGSTON OBSERVATORY, 58 - 59 MARKET PLACE, HULL, HU1 1RH · ENGLAND

Tel: 01482 223454 / 224412

Telex: 597636

Fax No.: 01482 219793

Technical Data on Reverse